

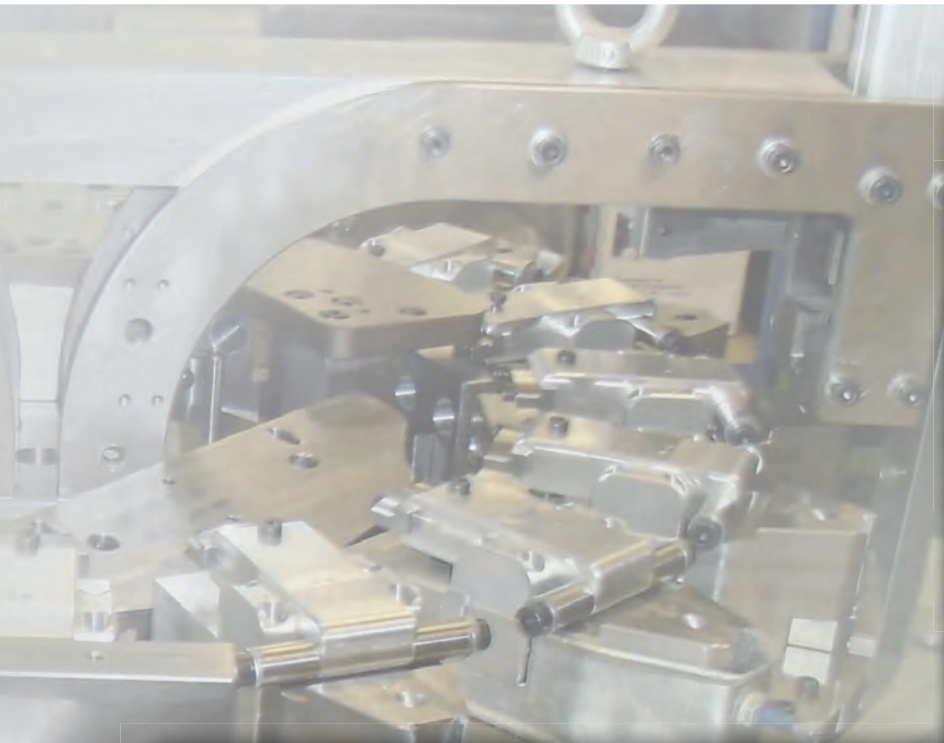

## TOOLS

- Base Frames
- Shear Plates
- Hydraulic Power Unit, hand pump
- Table Trolley
- Notching Tools
- Sheet Metal Punch
- Step Drill
- Mesh Cable Tray Cutting Tool





W-GG T..., W-SPOK T...

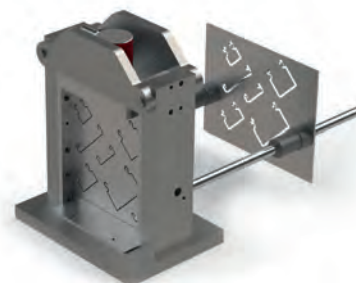

W-ALS 50X...



In order to facilitate the conventional processing of the channel systems by sawing and cutting, we have included various cutting systems in the range. The benefits for the customer are time savings, reduction of rejects and cost savings.

Channels and covers can be cut to length with low noise, precision and free of burrs in line with the contours. The handy notching tools also allow lateral notching in various dimensions, even on channels that have already been mounted. With the battery-operated hydraulic wire mesh gutter cutter, wire thicknesses of up to  $\varnothing$  6 mm can be processed.

W-HHA 360-3



W-GRSWS 1.5 AH



## Base Frame, Type 1

incl. hydraulic cylinder

Model No.	Max. force at 700 bar kN	Connection thread NPT	EAN code	Weight in kg per 100 pc.	Smallest packaging unit
★ <b>W-GG T1-Z15</b>	142	3/8"	185979	3590	1 pc.

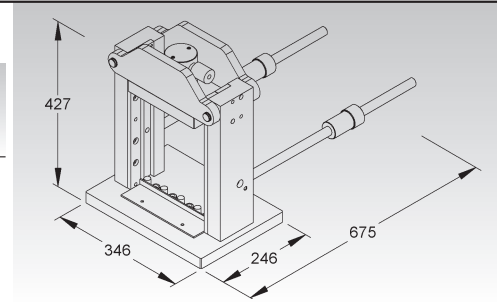

## Shear Plate, Type 1

incl. matching guide plate

Model No.	EAN code	Weight in kg per 100 Pair	Smallest packaging unit
<b>W-SPOK T1-20</b>	085415	1820	1 pair

for use, the basic frame type 1 is combined and operated with shear plate type 1 and the manual hydraulics (alternatively electric manual hydraulics)

**When ordering the shear plates, the contour for cutting to length must be ordered separately.**

Examples of shear plate contours:

- Base for cable protection / industrial trunking
- Cover for cable protection / industrial trunking
- Cable ducts
- C- and top-hat rails
- Barrier strips

Used for: base frame, type 1

Other shear plate contours available on request.

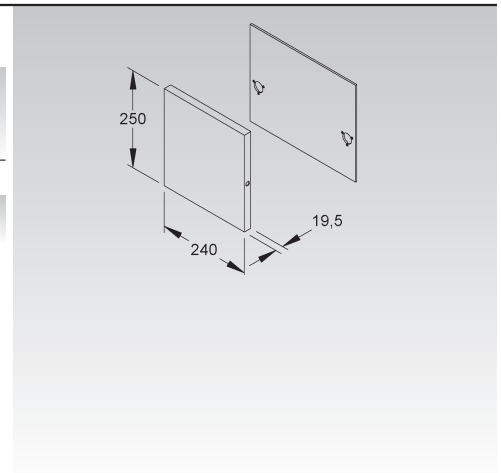

## Base Frame Stop System, Type 1

Model No.	EAN code	Weight in kg per 100 pc.	Smallest packaging unit
★ <b>W-GGAS T1</b>	184293	470	1 pc.

Used for: base frame, type 1

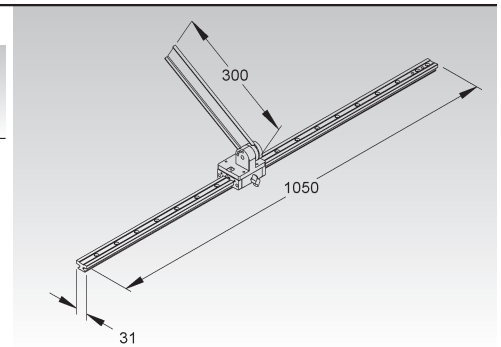

## Base Frame, Type 2

incl. hydraulic cylinder

Model No.	Max. force at 700 bar kN	Connection thread NPT	EAN code	Weight in kg per 100 pc.	Smallest packaging unit
★ <b>W-GG T2-Z15</b>	142	3/8"	185986	4840	1 pc.
★ <b>W-GG T2-Z25</b>	234	3/8"	185993	5040	1 pc.

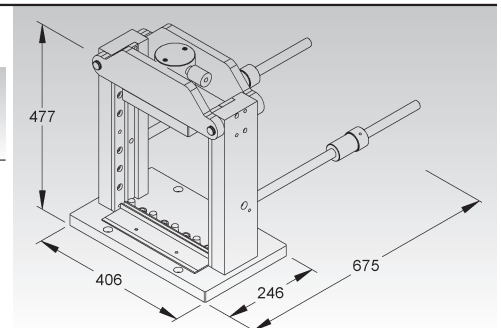

## Shear Plates, Type 2

incl. matching guide plate

Model No.	EAN code	Weight in kg per 100 Pair	Smallest packaging unit
<b>W-SPOK T2-20</b>	166350	2760	1 pair
<b>W-SPOK T2-30</b>	166367	4000	1 pair

for use, the basic frame type 2 is combined and operated with shear plate type 2 and the manual hydraulics (alternatively electric manual hydraulics)

**When ordering the shear plates, the contour for cutting to length must be ordered separately.**

**Examples of shear plate contours:**

- Base for cable protection / industrial trunking**
- Cover for cable protection / industrial trunking**
- Cable ducts**
- C- and top-hat rails**
- Barrier strips**

Used for: base frame, type 2

Other shear plate contours available on request.

W-SPOK T2-20

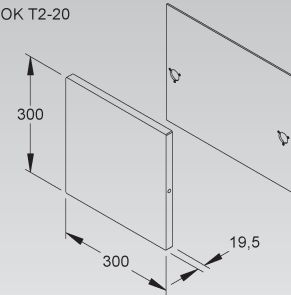

W-SPOK T2-30

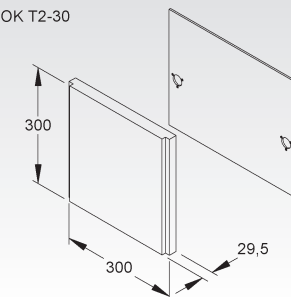

## Base Frame Stop System, Type 2

Model No.	EAN code	Weight in kg per 100 pc.	Smallest packaging unit
★ <b>W-GGAS T2</b>	184316	480	1 pc.

Used for: base frame, type 2

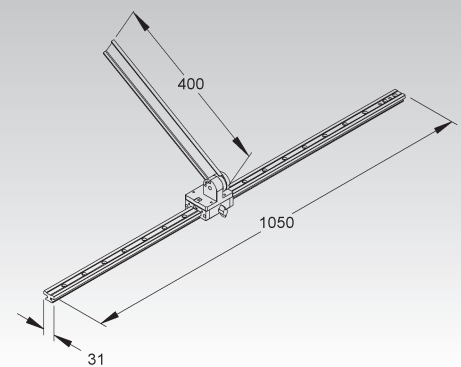

## Hydraulic Pump, manual

with pressure hose and coupler plug

Model No.	Max. pressure bar	Connection thread NPT	Oil vol. (tank) cm <sup>3</sup>	EAN code	Weight in kg per 100 pc.	Smallest packaging unit
★ <b>W-HPM 700</b>	700	3/8"	902	186013	940	1 pc.

Used for: base frame type 1 or type 2

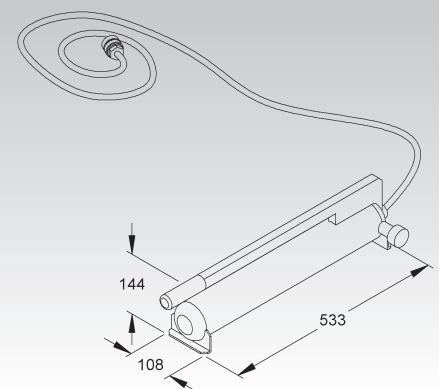

## Hydraulic Power Unit, electric

with pressure hose and coupler plug

Model No.	Max. pressure bar	Connection thread NPT	Oil vol. (tank) cm <sup>3</sup>	Power kW	Power freq. Hz	EAN code	Weight in kg per 100 pc.	Smallest packaging unit
★ <b>W-HPE 700</b>	700	3/8"	279	0,37	50/60	186006	2260	1 pc.

Used for: base frame type 1 or type 2

Nominal voltage: 230 V

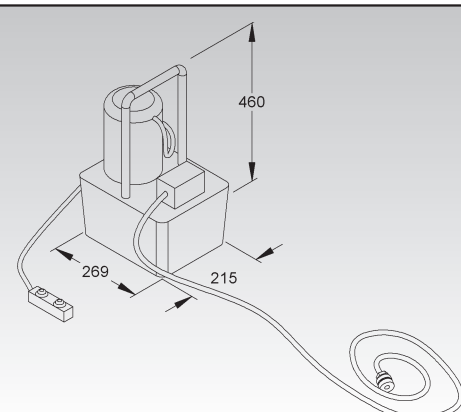

## Table Trolley

movable

Model No.	RAL colour	Height H	Width B	Length L	Table load capacity F	EAN code	Weight in kg per 100 pc.	Smallest packaging unit
		mm	mm	mm	kN			
★ W-TW 500-1	5007	860	609	737	5	167098	4100	1 pc.

The table trolley consists of:

- 2 steering castors with locking device
- 2 fixed castors
- 2 steel sheet platforms
- 1 handle

Used for: all body parts such as base frames incl. shear plates, hydraulic pump or hydraulic unit and collecting tray

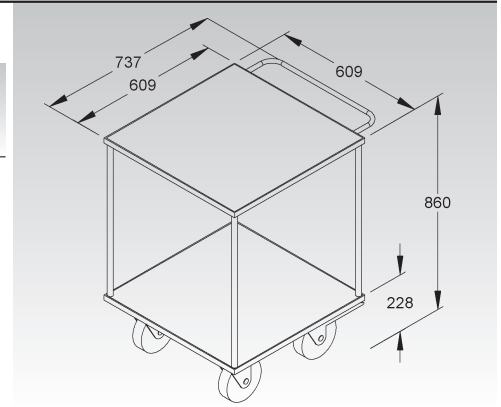

## Table Trolley

movable

Model No.	Height H	Width B	Length L	Table load capacity F	EAN code	Weight in kg per 100 pc.	Smallest packaging unit
	mm	mm	mm	kN			
★ W-TW 800-3-1/1100	850	700	1100	8	186037	9800	1 pc.

The table trolley (corpus RAL 7035) consists of:

- 2 steering castors with locking device
- 2 fixed castors
- 3 roller drawers (RAL 5005)
- 1 hinged door (RAL 5005)
- 1 beech worktop (thickness: 30 mm)
- 1 handle

Used for: all body parts such as base frames incl. shear plates, hydraulic pump or hydraulic unit and collecting tray

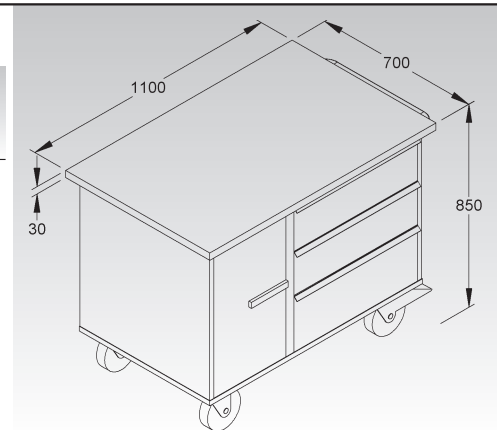

## Collection Tray

Model No.	Height H	Width B	Length L	EAN code	Weight in kg per 100 pc.	Smallest packaging unit
	mm	mm	mm			
★ E3 W-AW 44X580X1000 E3	44	580	1000	186129	1.144,93	1 pc.

Used for: table trolley

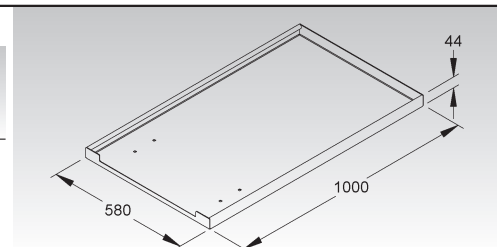

## Notching Tools

with UNF 19 connection thread

Model No.	Height H mm	EAN code	Weight in kg per 100 pc.	Smallest packaging unit
B <b>W-ALS 50X35</b>	80	163298	220	1 pc.
B <b>W-ALS 50X55</b>	100	154142	250	1 pc.

for notching rectangular holes (50 mm x 55 mm) into channel tray side rails

without drive unit

**The edge protection strip RKBA ... must be arranged as cable protection and in personal danger areas!**

Used for: cable protection ducts LLK... and LUK... from a height of 40 mm as well as industrial ducts LUE 60... and LI 60...

Required punching force of the drive unit 65 to 85 kN

Required stroke of the drive unit: 19 to 23 mm

W-ALS 50X35 - dimensions of notch (length x height) 50x35 mm, for duct height 40 mm

W-ALS 50X55 - dimensions of notch (length x height) 50x55 mm, for duct height 60 mm

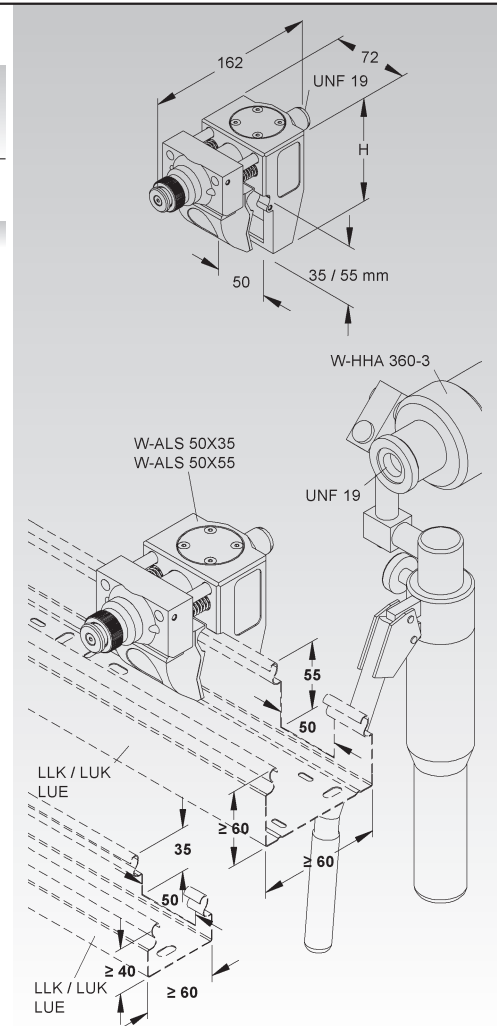

## Sheet Metal Punch

with adapter 3/4" (UNF 19) external thread - 1/2" internal thread

Model No.	Height H mm	Width B mm	EAN code	Weight in kg per 100 pc.	Smallest packaging unit
B <b>W-BL 20.65</b>	20	65	872121	108	1 pc.
B <b>W-BL 30.65</b>	30	65	872145	108	1 pc.

for onsite installation of cable entry openings measuring 20 x 65 mm or 30 x 65 mm in cable trays up to a material thickness of 2 mm (material 1.0226)

**For cable protection and in personal danger areas, the edge protection ring KSR... A must be used!**

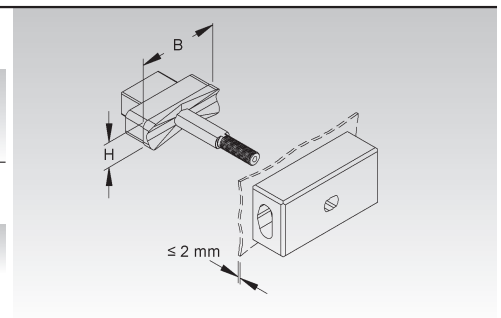

## Step Drill for Covers

Model No.	Height H mm	EAN code	Weight in kg per 100 pc.	Smallest packaging unit
B <b>W-SB 10.23</b>	170	872107	70	1 pc.

for onsite installation of turnbolt locks

**Drilling of the cover and milling off the aluminium chequer plate cover is carried out in one operation.**

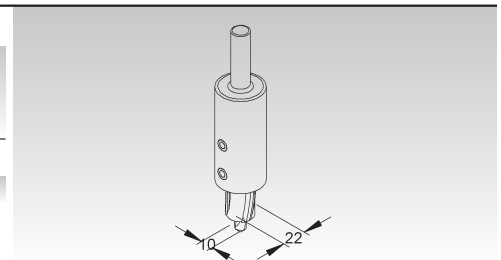

## Hydraulic Hand Pump

manual hydraulic pump with UNF 19 (3/4") connection thread and three 360° rotatable axes, max. force 70 kN

Model No.	Height H mm	Length L mm	EAN code	Weight in kg per 100 pc.	Smallest packaging unit
<b>W-HHA 360-3</b>	150	420	186440	200	1 pc.



Used for: notching tool W-ALS 50X35 and W-ALS 50X55  
sheet metal punch W-BL 20.65 and W-BL 30.65, special tool

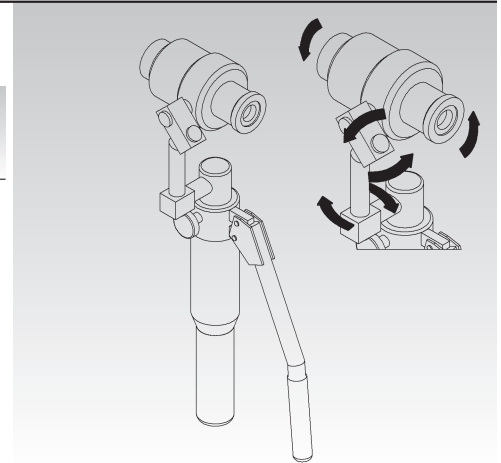

## Mesh Cable Tray Cutting Tool Set

with battery and charger

Model No.	Height H mm	Length L mm	EAN code	Weight in kg per 100 pc.	Smallest packaging unit
<b>W-GRSWS 1.5 AH</b>	115	350	110780	475	1 pc.

for separating the mesh tray bars

Used for: mesh cable trays up to 6 mm wire diameter

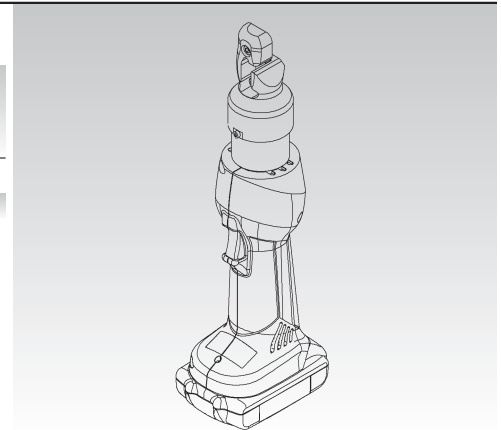

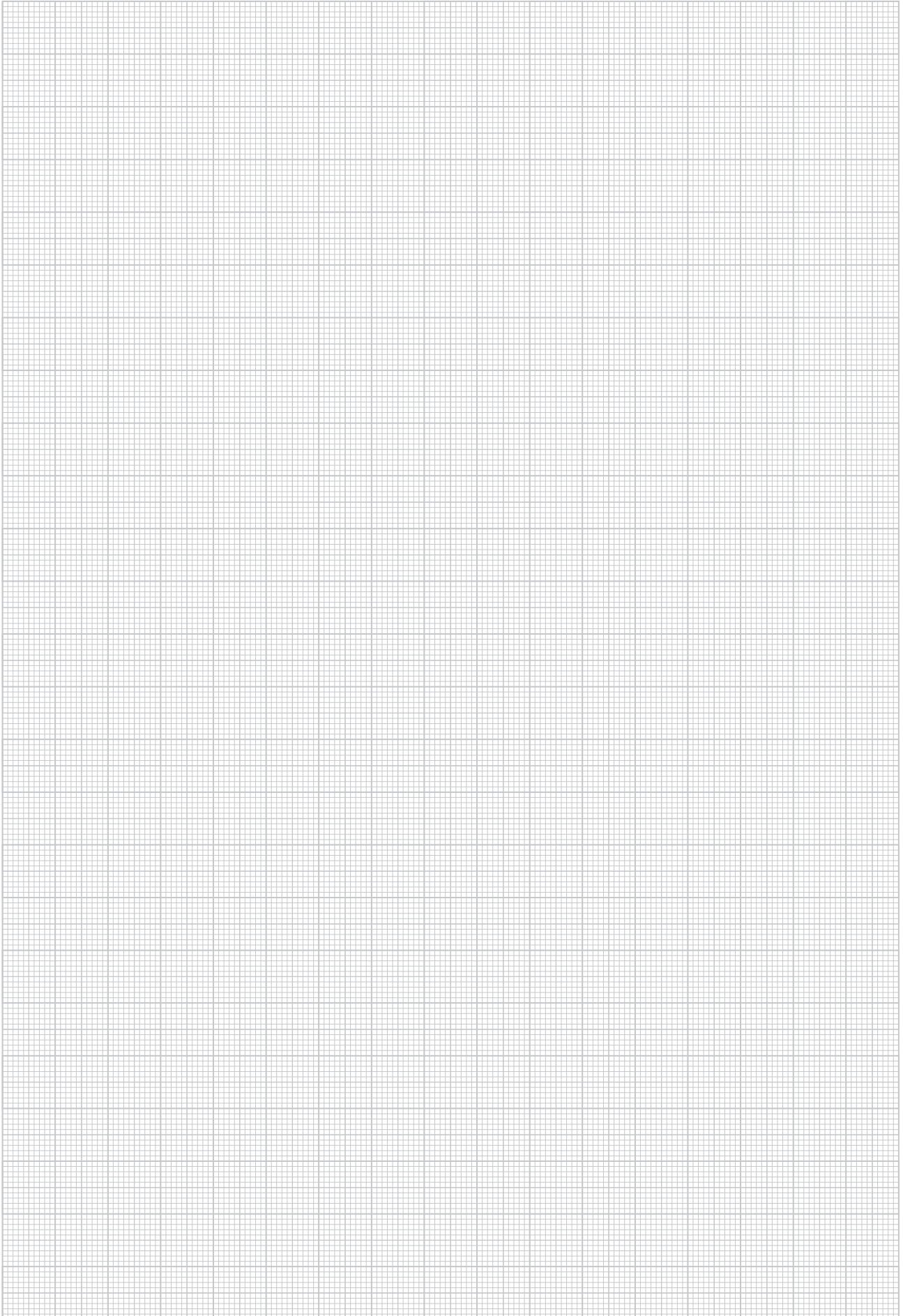

NOTES

A large rectangular area filled with a fine grid of light gray lines, intended for taking notes. The grid consists of small squares, approximately 20x20 units in size, covering the majority of the page's content area.